

SP-42AF-00

# FIS GAS SENSOR SP-42AF-00

## for REFRIGERANT DETECTION

The SP-42AF is a tin dioxide semiconductor gas sensor which has a high sensitivity to HFCs (e.g. Freon: R134a) with improved cross sensitivity to other gases. This model is suitable for R134a, R410A, R404A, R32 and other new Freon family which contain R-134a.

### Structure

Gas sensitive semiconductor material is formed on the alumina substrate on which the gold electrodes are printed. A thick film heater of ruthenium oxide is printed on the reverse of the substrate and placed in the plastic housing which uses double stainless steel mesh (100 mesh) in the path of gas flow. This sensor has silicon poison proof silica filter (Fig 1).

### Operating conditions

Fig 2 shows the standard operating circuit for this model. The change of the sensor resistance ( $R_S$ ) is obtained as the change of the output voltage across the fixed or variable resistor ( $R_L$ ). In order to obtain the best performance and specified characteristics, the values of the heater voltage ( $V_H$ ) circuit voltage ( $V_C$ ) and load resistance ( $R_L$ ) must be within the range of values given in the standard operating conditions shown in the Specification table on the next page.

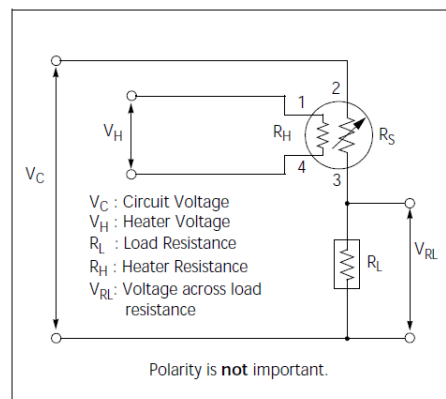

Fig 2. Standard circuit

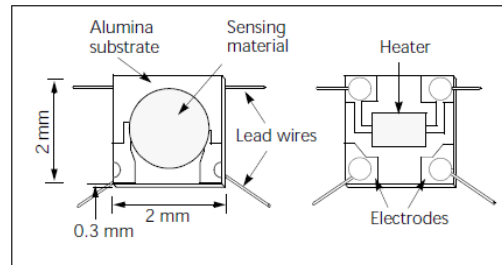

Fig 1a. Sensing element

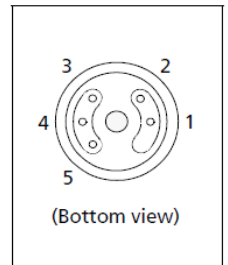

Fig 1c. Pin Layout

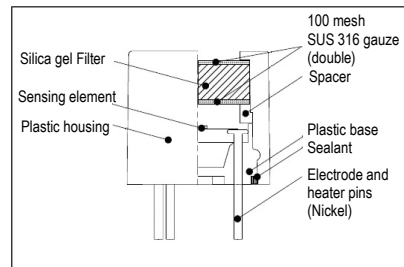

Fig 1b. Configuration

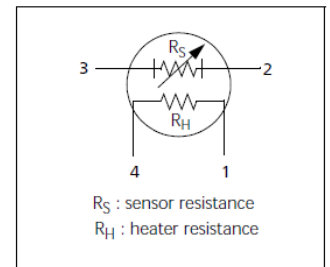

Fig 1d. Equivalent circuit

### Sensitivity characteristics

Fig 3 shows the sensitivity characteristics curves of the SP-42AF (typical data). Sensitivity characteristics of the FIS gas sensors are expressed by the relationship between the sensor resistance and gas concentration. The sensor resistance decreases with an increase of gas concentration based on a logarithmic function.

The sensitivity characteristics of the SP-42AF is specified by the following parameters.

- Sensor resistance level: at 100 ppm of R134a
- Sensor resistance change ratio: between R134a 100ppm and 1000 ppm
- Sensitivity of R134a: the sensor resistance ratio of between in air and at R134a 100ppm

See the specification table on the next page for further details.

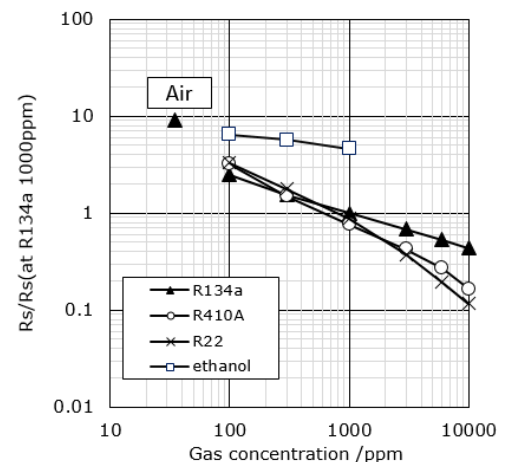

Fig 3. Sensitivity characteristics

# Specifications: SP-42AF-00

## A. Standard operating conditions

Symbol	Parameter	Specification	Conditions etc.
VH	Heater voltage	5.0 V ± 4%	AC or DC
VC	Circuit voltage	5.0 V ± 4%	AC or DC
RL	Load resistance	Variable (>200Ω)	PS < 15 mW
RH	Heater resistance	40Ω ± 2Ω	at room temperature
IH	Heater current	80 mA (Typical value)	IH = VH / RH
PH	Heater power consumption	400 mW (Typical value)	at VH=5V
PS	Power dissipation of sensing element	Less than 15mW	$P_S = \frac{(V_C - V_{RH})^2}{R_S}$

## B. Environmental conditions

Symbol	Parameter	Specification	Conditions etc.
T <sub>ao</sub>	Operating temperature	-10 °C to 50 °C	
T <sub>as</sub>	Storage temp	-20 °C to 60 °C	
RH	Relative humidity	Less than 95%RH (Do not condense into dew)	
(O <sub>2</sub> )	Oxygen concentration	21% ± 1% (Standard condition) The sensitivity characteristics are influenced by the variation in oxygen concentration. Please consult FIS for details.	Absolute minimum level : more than 18%.
Others		Exposure to solvents and/or silicone compounds must be avoided. Sensitivity characteristics may be effected.	

## C. Sensitivity characteristics

Model	SP-42AF-00		
Symbol	Parameter	Specification	Conditions etc.
R <sub>s</sub>	Sensor resistance	10kΩ ~ 100kΩ	at 100 ppm of R134a
β	Sensitivity	0.25 ~ 0.40	$\frac{R_s (R134a 1000 ppm)}{R_s (R134a 100 ppm)}$
Sensitivity of R134a		less than 0.40	$\frac{R_s (R134a 100 ppm)}{R_s (in air)}$
Standard Test Conditions:		Temp: 20 °C ± 2 °C Humidity: 65% ± 5% (in clean air) Pre-heating time: more than 48hours	

## D. Mechanical characteristics

Items	Conditions	Specifications
Vibration	Frequency: 5 -500 Hz	Should satisfy the specifications shown in the C.Sensitivity characteristics after test
	Acceleration: 1.3G	
Sweep Time: 40min.		
Drop	Height: 60 cm	
	Number of impacts: 3 times	

Please contact

## Dimensions

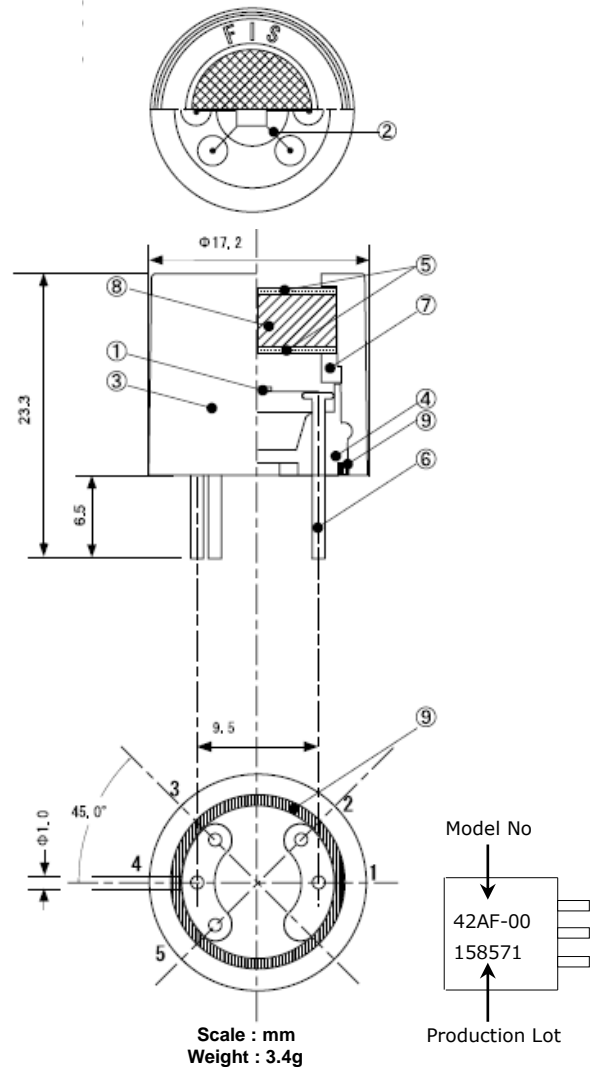

## E. Parts and Materials

No.	Parts	Materials
①	Sensing element	Tin dioxide
②	Frame proof	Noble metal alloy
③	Plastic housing	Nylon 46 (UL94HB, blue)
④	Plastic base	Nylon 46 (UL94HB, blue)
⑤	Mesh	SUS316 (100mesh,
⑥	Electrode pin	Nickel plated brass
⑦	Spacer	Nylon 46 (UL94HB, blue)
⑧	Filter	Silica gel
⑨	Sealant	Elastic resin sealant

JANUARY, 2018

Nissha FIS, Inc.  
3-36-3,Kitazono  
Itami,Hyogo  
664-0891 Japan

Tel: +81-72-780-1800  
Fax: +81-72-785-0073  
<http://www.fisinc.co.jp>

In the interest of continued product improvement, we reserve the right to change design features without prior